



LABJET

Efficiency and accuracy of the water jet cutting combined in a compact size with industrial performances.



Other products of the WATER JET PRODUCT RANGE



Mecajet II
Equipment for the very high-pressure water jet cutting



Quickjet II
Closed water jet cutting equipment dimension 1000x1200 mm



MDE
Pure water jet cutting equipment

STRENGTHS

- Compact equipment with integrated high-pressure pump.
- Fixed table in working area 1050 x 750 mm.
- Cutting of soft materials with pure water (rubber, plastic materials, foam, leather...) and hard materials (metal, glass, stone, composites materials...) with abrasive option.
- High pressure pumps 4136 bars.
- Driving system with numerical control CN9000 ISO and CAM software with specific applications for water jet cutting.
- 2D cutting head.
- Quality kinematic integrating industrial components supplied by the world leaders in their respective fields, mounted on monoblock frames in welded steel with integrated tank.
- Protections of the axes by bellows for the whole components exposed to water and abrasive.
- Machine completely closed, can be operated safely even in school environment or general public.

The LABJET is the ideal machine to meet the requirements of the industrials regarding accuracy and precision while controlling their budget. Delivered in a versatile format. Proposed with a high-pressure pump 4136 bars of 10 to 20 HP, this machine enables the pure water jet cutting of soft materials or abrasive water cutting for hard materials. Compact and easy to use, the LABJET combines precision, power and security for the industrial works.



Listening



Custom-made



Multi-technologies



100% integrated

LABJET

The LABJET is equipped with a monoblock welded steel frame with an integrated waste water collecting tank and aluminium gantry. The table top is made of galvanized steel for abrasive cutting or with plastic honeycomb coating for pure water cutting.

The LABJET kinematic includes guidance by rectified rails and ball bearings, the XY transmission is equipped with ball screws and « AC Brushless » servomotors motorisation.

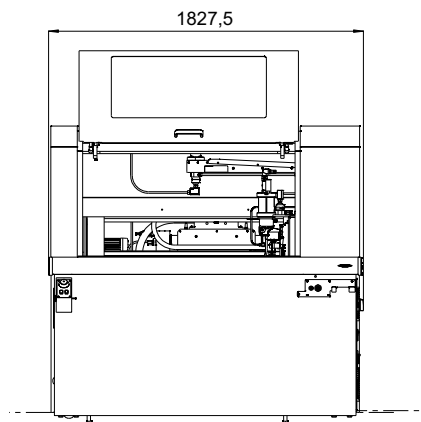
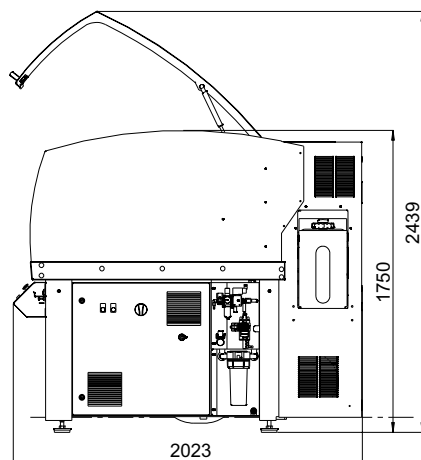

FEATURES

X-axis travels in mm	1050
Y-axis travels in mm	750
A-axis travels in mm (manual axis)	50
Maximum dimensions of the plates in the tank in m	1200x1000
Maxi speed in m/min	12
Acceleration in m.s ²	1
Repeatability in mm at 20°C +/- 2°	±0.06

CUTTING HEAD

- Pure water cutting head
- Abrasive cutting head

OPTIONS AND ACCESSORIES

- Separate abrasive tank 250 kg
- Plotting visible laser
- Ballast for immersion work
- Water softener

ABRASIVE (OPTIONNAL)

- Abrasive tank 30L
- Abrasive measuring dispenser

DIMENSIONS

Overall length in mm	2024
Overall width in mm	1826
Height in mm, closed cover / opened cover	1750-2440
Weight in kg empty tank (about)	1600

SUPPLIES

Air supply	6 bars - 6 m ³ /h
Power supply 400 V three phased at 50 Hz + ground	
- 10 HP pump	8 kW / 16 A per phase
- 20 HP pump	16 kW / 32 A per phase

POMPES

10 HP pump – air heater cooling	4136 bars
20 HP pump – air heater cooling	4136 bars
Cooling unit	as option

